



**2024**

**Bakfiets.nl** has changed the look of cycling in the Netherlands, United Kingdom and many other countries. Their concept of carrying children in a cargo bike was innovative and is now accepted world-wide as an alternative and green form of transport. For many parents using a Bakfiets.nl Cargobike or Cargotrike is a liberating and life changing experience especially on the school run in busy towns and cities where the volume of traffic has become a big problem. Since the first model, there has been continuing development to enable you to carry babies, children, dogs, shopping and cargo with ease and in safety.



## → Electric Assist

Almost all CargoBikes and Trikes are available with an electric driven assist motor. This makes cycling more comfortable (lighter and faster). The motor can also be used to assist you while pushing the bike.

The battery is in most cases mounted to the frame, but with the three wheeled bikes it is mounted in the rear rack.

## → Shimano STEPS

All the Cargobikes and Trikes make use of the Shimano Steps (DU6100). This powerful motor is light and reliable, and is located at the bottom bracket. The motor has a good range and long battery life. The handlebar mounted display is simple to use and has a handlebar mounted toggle switch to change between the functions and power settings. There is even a walk function for pedestrianised areas when dismounted. The STEPS system delivers standard **50Nm**, with the Enviolo and Shimano nexus 5 hub even **60Nm**, with **250w**.

### Available gear options

Steps is available in combination with different gear options: Bafang 3 speed automatic, Shimano Di2 5 speed hub with electronic gear changer, Shimano 5 speed mechanical gear and Enviolo continuously variable hub gear

### Nexus 5 speed hub

This hub is specially made for use in cargo bikes combined with a mid-engine. It has a sturdier build so it can withstand more force than a nexus 7 or 8 speed hub

### Di2

The Di2 version is fully integrated with the motor and by means of electronic control the motor automatically reduces power slightly to enable smooth electronic gear shifting. The system automatically shifts down when coming to a halt therefore you are in the right gear to set off again. Or you can choose to manually select the gears with the toggle switch on the handlebar.

### Battery

We deliver the bikes standard with a 418Wh battery, optionally there can be chosen for the upgraded 504Wh version, which has a 20% larger operating range.

## → Operating Range

**Pay attention:** for a Cargobike its hard to specify the exact operation range.

The operation range can vary between 25 km and 70 km (15 and 50 miles). This depends on the total weight (rider + load) of the Cargobike, the level of assistance chosen from the motor. The terrain to be covered—flat—hilly or mountainous. City or country environments will have a big influence, stopping and starting especially. Its possible to increase the operation range by driving away in a low gear and by making sure that the tires are inflated.



## → Bafang M400

The electric CargoBikes long and Trikes can be equipped with the Bafang mid-engine system (M400 series). This system is relatively light in weight, provides good support and has a large range. Bafang has become a major player in the field of electric bicycles, the motor delivers no less than 80Nm at 250 watts, making it a more powerful motor than the Shimano 6100 series.

### Available gear options

The Bafang models are available with a Bafang 3 speed hub automatic, NuVinci stepless gear hub or a Shimano nexus 5 gear hub manual transmission.

### Nexus 5 versnellingsnaaf

This hub is specially made for use in cargo bikes combined with a mid-engine. It has a sturdier build so it can withstand more force than a nexus 7 or 8 speed hub

### Battery

The Bafang bicycles are supplied with a large 750Wh battery as standard.

## → Operating Range

**Pay attention:** for a Cargobike its hard to specify the exact operation range. The operation range can vary between 35 km and 90 km (15 and 50 miles). This depends on the total weight (rider + load) of the Cargobike, the level of assistance chosen from the motor. The terrain to be covered—flat—hilly or mountainous. City or country environments will have a big influence, stopping and starting especially. Its possible to increase the operation range by driving away in a low gear and by making sure that the tires are inflated.

## → E-bikes and Nm

Newton meter indicates how large the torque is. Torque is the turning force that the motor can deliver. The more torque, the more powerful the motor.

### How powerful should the engine be?

If you cycle a lot on flat terrain, with the occasional small hill, then 50 to 60 Nm meters should be sufficient, if you live / cycle a lot in hilly areas, then a stronger engine with 80 Nm is absolutely recommended, we recommend also the bafang motor for these areas.



## E-CargoBike Classic Short

The CargoBike classic short Steps is a traditional CargoBike with the Shimano Steps motor. The motor is mounted in the bottom bracket. The motor detects rotation, cadence and torque to give you smooth power assistance.

Dimensions: CargoBike short: length 228cm x width 63cm.

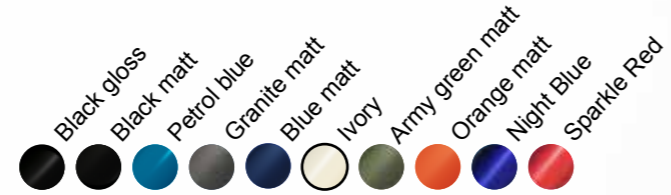

Discover this bike on our website or click through and discover our configurator

### → Available gear options

Rollerbrakes:	Steps
Shimano 5v Mechanical:	<b>NN5:</b> v
Shimano 5v Di2:	<b>NN5 Di2:</b> v
Shimano 7v:	<b>NN7:</b> v
Disc brakes:	
Bafang 3v Automatic:	<b>SS3:</b> v
Shimano 5v Mechanical:	<b>SS5:</b> v
Shimano 5v Di2:	<b>SS5 Di2:</b> v
Shimano 7v:	<b>SS7:</b> v
Enviolo:	<b>SSi:</b> v
Magura HS11 rim brakes:	
Bafang 3v Automatic:	<b>MM3:</b> v
Shimano 5v Mechanical:	<b>MM5:</b> v
Shimano 5v Di2:	<b>MM5 Di2:</b> v
Shimano 7v :	<b>MM7:</b> v
Enviolo:	<b>MMi:</b> v

→ Accessories (See page. 30 to 35)



## E-CargoBike Cruiser Short

A vintage version similar to the CargoBike Classic Steps, but with fat tyres for comfort, mudguards in matching frame colour, Brooks Aged leather saddle and handlebar grips, a retro style 35 lux headlight and Plateo rear light.

Dimensions CargoBike short: Length 228cm x width 63cm

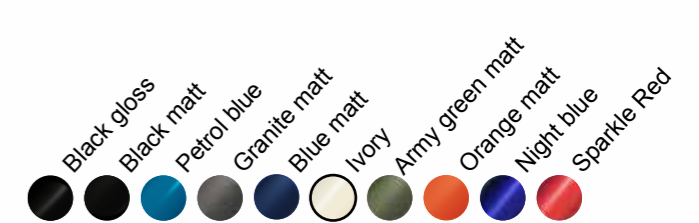

Discover this bike on our website or click through and discover our configurator

### → Available gear options

Rollerbrakes:	Steps
Shimano 5v Mechanical:	<b>NN5:</b> v
Shimano 5v Di2:	<b>NN5 Di2:</b> v
Shimano 7v:	<b>NN7:</b> v
Disc brakes:	
Bafang 3v Automatic:	<b>SS3:</b> v
Shimano 5v Mechanical:	<b>SS5:</b> v
Shimano 5v Di2:	<b>SS5 Di2:</b> v
Shimano 7v:	<b>SS7:</b> v
Enviolo:	<b>SSi:</b> v
Magura HS11 rim brakes:	
Bafang 3v Automatic:	<b>MM3:</b> v
Shimano 5v Mechanical:	<b>MM5:</b> v
Shimano 5v Di2:	<b>MM5 Di2:</b> v
Shimano 7v :	<b>MM7:</b> v
Enviolo:	<b>MMi:</b> v

→ Accessories (See page. 30 to 35)





## E-CargoBike Classic Long

The CargoBike classic long Steps is a traditional CargoBike with the Shimano Steps motor. The motor is mounted in the bottom bracket. The motor detects rotation, cadence and torque to give you smooth power assistance. Due to the longer box there is more space available for accessories such as the Maxi-Cosi or an extra bench.  
Dimensions CargoBike long: length 253cm x width 63cm.

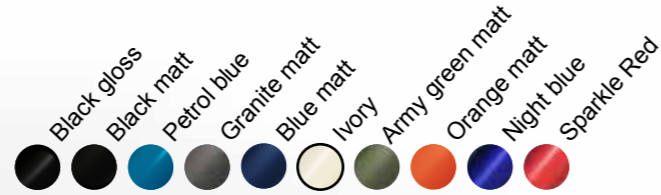

Discover this bike on our website or click through and discover our configurator

### → Available gear options

	Steps	Bafang
<b>Rollerbrakes:</b>		
Shimano 5v Mechanical:	<b>NN5:</b> v	v
Shimano 5v Di2:	<b>NN5 Di2:</b> v	
Shimano 7v:	<b>NN7:</b> v	
<b>Disc brakes:</b>		
Bafang 3v Automatic:	<b>SS3:</b> v	v
Shimano 5v Mechanical:	<b>SS5:</b> v	v
Shimano 5v Di2:	<b>SS5 Di2:</b> v	
Shimano 7v:	<b>SS7:</b> v	
Enviolo:	<b>SSi:</b> v	v
<b>Magura HS11 rim brakes:</b>		
Bafang 3v Automatic:	<b>MM3:</b> v	v
Shimano 5v Mechanical:	<b>MM5:</b> v	v
Shimano 5v Di2:	<b>MM5 Di2:</b> v	
Shimano 7v :	<b>MM7:</b> v	
Enviolo:	<b>MMi:</b> v	v

→ Accessories  
(See page. 30 to 35)



## E-CargoBike Cruiser Long

Similar to the CargoBike Classic Long Steps, but a vintage version with mudguards in matching frame colour, Brooks Aged leather saddle and handlebar grips, a retro style 35 lux headlight and Plateau rear light.  
Dimensions CargoBike long: Length 253cm x width 63cm



Discover this bike on our website or click through and discover our configurator

### → Available gear options

	Steps	Bafang
<b>Rollerbrakes:</b>		
Shimano 5v Mechanical:	<b>NN5:</b> v	v
Shimano 5v Di2:	<b>NN5 Di2:</b> v	
Shimano 7v:	<b>NN7:</b> v	
<b>Disc brakes:</b>		
Bafang 3v Automatic:	<b>SS3:</b> v	v
Shimano 5v Mechanical:	<b>SS5:</b> v	v
Shimano 5v Di2:	<b>SS5 Di2:</b> v	
Shimano 7v:	<b>SS7:</b> v	
Enviolo:	<b>SSi:</b> v	v
<b>Magura HS11 rim brakes:</b>		
Bafang 3v Automatic:	<b>MM3:</b> v	v
Shimano 5v Mechanical:	<b>MM5:</b> v	v
Shimano 5v Di2:	<b>MM5 Di2:</b> v	
Shimano 7v :	<b>MM7:</b> v	
Enviolo:	<b>MMi:</b> v	v

→ Accessories  
(See page. 30 to 35)





# Shadow

The Shadow has an aluminum frame, Shimano Steps mid-engine, aluminum profile box with trampoline fabric. This model is the lightest and stiffest cargobike within our product range due to the aluminium double walled spiderweb tube in the frame. This makes cycling on this cargo bike a natural experience. The hydraulic brakes and strong rims make the Shadow a very stable and safe cargobike. The dimension of the box are equal to the CargoBike Long, so most accessories will fit. Dimensions Shadow: length 253cm x width 63cm.

- Black gloss
- Black matt
- Petrol blue
- Granite matt
- Blue matt
- Ivory
- Army green matt
- Orange matt
- Night blue
- Sparkle Red



Discover this bike on our website or click through and discover our configurator

## → Available gear options

Rollerbrakes:		Steps
Shimano 5v Mechanical:	<b>NN5:</b>	v
Shimano 5v Di2:	<b>NN5 Di2:</b>	v
Shimano 7v:	<b>NN7:</b>	v
Disc brakes:		
Bafang 3v Automatic:	<b>SS3:</b>	v
Shimano 5v Mechanical:	<b>SS5:</b>	v
Shimano 5v Di2:	<b>SS5 Di2:</b>	v
Shimano 7v:	<b>SS7:</b>	v
Enviolo:	<b>SSi:</b>	v
Magura HS11 rim brakes:		
Bafang 3v Automatic:	<b>MM3:</b>	v
Shimano 5v Mechanical:	<b>MM5:</b>	v
Shimano 5v Di2:	<b>MM5 Di2:</b>	v
Shimano 7v :	<b>MM7:</b>	v
Enviolo:	<b>MMi:</b>	v



→ Accessories  
(See page. 30 to 35)





## Shepherd Steps

The Shepherd is the top model of Bakfiets.nl. With its aluminum frame, Shimano Steps mid-engine and EPP box, this model is light and super stiff. This makes cycling on this cargo bike a real experience. The aluminum frame is made of engineered double-walled aluminum tubes. The hydraulic brakes and the strong rims make the Shepherd very solid and safe. **Please note, not all accessories are applicable.** Sizes Shepherd: length 265cm x width 71cm.



- Black gloss
- Black matt
- Petrol blue
- Granite matt
- Blue matt
- Ivory
- Army green matt
- Orange matt
- Night blue
- Sparkle Red



Discover this bike on our website or click through and discover our configurator

### → Available gear options

<b>Rollerbrakes:</b>		<b>steps</b>
Shimano 5v Mechanical:	<b>NN5</b>	<b>V</b>
Shimano 5v Di2:	<b>NN5 DI2</b>	<b>V</b>
<b>Disc brakes:</b>		
Bafang 3v Automatic:	<b>SS3</b>	<b>V</b>
Shimano 5v Mechanical:	<b>SS5</b>	<b>V</b>
Shimano 5v Di2:	<b>SS5 DI2</b>	<b>V</b>
Enviolo	<b>SSi</b>	<b>V</b>
<b>Magura HS11 rim brakes:</b>		
Shimano 5v Mechanical:	<b>MM5</b>	<b>V</b>
Shimano 5v Di2:	<b>MM5 DI2</b>	<b>V</b>
Enviolo:	<b>MMi</b>	<b>V</b>

### → Accessories



76. Canopy Shepherd



77. Coverall Shepherd



## Shepherd Bafang

The Shepherd is the top model of Bakfiets.nl. With the Bafang model, a very stiff steel frame is mounted, and of course this bike has a powerful Bafang M400 motor and EPP box. This makes cycling on this cargo bike a real experience. The hydraulic brakes and the strong rims make the Shepherd very solid and safe. **Please note, not all accessories are applicable.** Sizes Shepherd: length 265cm x width 71cm.



- Black gloss
- Black matt
- Petrol blue
- Granite matt
- Blue matt
- Ivory
- Army green matt
- Orange matt
- Night blue
- Sparkle Red



Discover this bike on our website or click through and discover our configurator

### → Available gear options

<b>Rollerbrakes:</b>		<b>Bafang</b>
Shimano 5v Mechanical:	<b>NN5</b>	<b>V</b>
<b>Disc brakes:</b>		
Bafang 3v Automatic:	<b>SS3</b>	<b>V</b>
Shimano 5v Mechanical:	<b>SS5</b>	<b>V</b>
Enviolo	<b>SSi</b>	<b>V</b>
<b>Magura HS11 rim brakes:</b>		
Bafang 3v Automatic:	<b>MM3</b>	<b>V</b>
Shimano 5v Mechanical:	<b>MM5</b>	<b>V</b>
Enviolo:	<b>MMi</b>	<b>V</b>

The Bafang system is standard available with the big 750wh battery

### → Accessories



76. Canopy Shepherd



77. Coverall Shepherd





## E-CargoTrike Classic Narrow

The trike has more space than the Cargobike. As standard there is room for four children. One of the benefits of the trike is the stability of the bike at lower speeds. **Take note that:** a lot of people still prefer the Cargobike due to the higher maneuverability of the bike.

Dimensions trike narrow: length 210cm x width 85 cm.  
Dimensions bottom surface: length 86cm x width 54cm.



Discover this bike on our website or click through and discover our configurator

### → Available gear options

Rollerbrakes:	steps	Bafang
Shimano 5v Mechanical:	<b>NN5</b>	V
Shimano 5v Di2:	<b>NN5 Di2</b>	V
Shimano 7v:	<b>NN7</b>	V
Disc brakes:		
Bafang 3v Automatic:	<b>SS3</b>	V
Shimano 5v Mechanical:	<b>SS5</b>	V
Shimano 5v Di2:	<b>SS5 Di2</b>	V
Shimano 7v:	<b>SS7</b>	V
Enviolo	<b>SSi</b>	V



→ Accessories  
(See page. 30 to 35)



## E-CargoTrike Cruiser Narrow

The Cargotrike narrow cruiser is a trike with a modern "vintage" appearance due to its creme fat tires, retro style 35 lux headlights, Brooks Aged leather saddle and handlebar grips. All Trikes are equipped with a steering stabilizer. This provides stable steering and prevents sudden change of direction when one wheel hits a small pit.

Dimensions trike narrow: length 210cm x width 85 cm.  
Dimensions bottom surface: length 86cm x width 54cm.

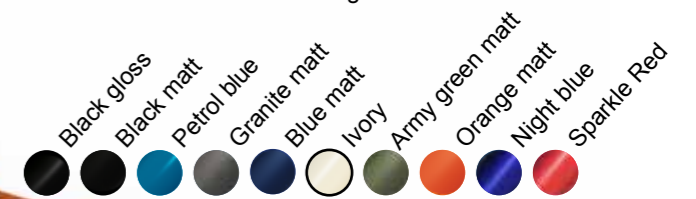

Discover this bike on our website or click through and discover our configurator

### → Available gear options

Rollerbrakes:	steps	Bafang
Shimano 5v Mechanical:	<b>NN5</b>	V
Shimano 5v Di2:	<b>NN5 Di2</b>	V
Shimano 7v:	<b>NN7</b>	V
Disc brakes:		
Bafang 3v Automatic:	<b>SS3</b>	V
Shimano 5v Mechanical:	<b>SS5</b>	V
Shimano 5v Di2:	<b>SS5 Di2</b>	V
Shimano 7v:	<b>SS7</b>	V
Enviolo	<b>SSi</b>	V



→ Accessories  
(See page. 30 to 35)





## E-CargoTrike Classic Wide

The wide version of the trike has a better road handling due to the bigger distance between the front weels. The box also has a bigger capacity. There is also standard room for four children. Dimensions trike wide: length 210cm x width 95 cm. Dimensions bottom surface: length 86 cm x width 65 cm.



- Black gloss
- Black matt
- Petrol blue
- Granite matt
- Blue matt
- Ivory
- Army green matt
- Orange matt
- Night blue
- Sparkle Red



Discover this bike on our website or click through and discover our configurator

### → Available gear options

Rollerbrakes:	steps	Bafang
Shimano 5v Mechanical:	<b>NN5</b>	V
Shimano 5v Di2:	<b>NN5 Di2</b>	V
Shimano 7v:	<b>NN7</b>	V
Disc brakes:	steps	Bafang
Bafang 3v Automatic:	<b>SS3</b>	V
Shimano 5v Mechanical:	<b>SS5</b>	V
Shimano 5v Di2:	<b>SS5 Di2</b>	V
Shimano 7v:	<b>SS7</b>	V
Enviolo	<b>SSi</b>	V

#### Tip:

Order your trike with disc brakes at the front and an extremely good parking brake.



→ Accessories (See page. 30 to 35)



## E-CargoTrike Cruiser Wide

The Cargotrike wide cruiser is a trike with a modern "vintage" appearance due to its creme fat tires, Brooks Aged leather saddle and handlebar grips and retro style 35 lux headlights. All Trikes are equipped with a steering stabilizer.

**Take note off:** In the cruiser trikes the battery is mounted in the carrier (this carrier is also compatible with a child seat). Dimensions trike wide: length 210cm x width 95 cm. Dimensions bottom surface: length 86 cm x width 65 cm.



- Black gloss
- Black matt
- Petrol blue
- Granite matt
- Blue matt
- Ivory
- Army green matt
- Orange matt
- Night blue
- Sparkle Red



Discover this bike on our website or click through and discover our configurator

### → Available gear options

Rollerbrakes:	steps	Bafang
Shimano 5v Mechanical:	<b>NN5</b>	V
Shimano 5v Di2:	<b>NN5 Di2</b>	V
Shimano 7v:	<b>NN7</b>	V
Disc brakes:	steps	Bafang
Bafang 3v Automatic:	<b>SS3</b>	V
Shimano 5v Mechanical:	<b>SS5</b>	V
Shimano 5v Di2:	<b>SS5 Di2</b>	V
Shimano 7v:	<b>SS7</b>	V
Enviolo	<b>SSi</b>	V

→ Accessories (See page. 30 to 35)





# 25 years of Bakfiets.nl

When the idea of developing a cargo bike to safely transport children was born in 1999, we never thought it would be such a success.

Where a cargo bike used to be a heavy, old-fashioned three-wheeled cargo bike, we have changed that with our product. When you think of a cargo bike these days, you almost immediately think of the cargo bike in its current form for transporting children.

Now we are 25 years later and the original concept is still the same, visually the classic model is even similar to the model we introduced 25 years ago. Mechanically nothing is the same as before and every part has been adapted to today's standards.

This year, in honor of our 25th anniversary, we are introducing a specially designed safety bar for added safety, along with our new unique configurator to help you create your dream cargo bike which you can put together yourself.

Discover our configurator yourself and go to our website to design your own beautiful cargo bike.  
www.bakfiets.nl



**MyBakfiets.nl**  
designed by you



# E-Anniversary Long

Bakfiets.nl has been producing cargo bikes for 25 years. Reason enough to develop this special anniversary version with safety at its core.

This version is characterized by the safe safety roll bars, the colored trim and the black colored box.

Dimensions CargoBike Long: length 253 cm x width 63 cm.



## → Available gear options

	Steps	Bafang
<b>Rollerbrakes:</b>		
Shimano 5v Mechanical:	<b>NN5:</b> v	v
Shimano 5v Di2:	<b>NN5 Di2:</b> v	
Shimano 7v:	<b>NN7:</b> v	
<b>Disc brakes:</b>		
Bafang 3v Automatic:	<b>SS3:</b> v	v
Shimano 5v Mechanical:	<b>SS5:</b> v	v
Shimano 5v Di2:	<b>SS5 Di2:</b> v	
Shimano 7v:	<b>SS7:</b> v	
Enviolo:	<b>SSi:</b> v	v
<b>Magura HS11 rim brakes:</b>		
Bafang 3v Automatic:	<b>MM3:</b> v	v
Shimano 5v Mechanical:	<b>MM5:</b> v	v
Shimano 5v Di2:	<b>MM5 Di2:</b> v	
Shimano 7v :	<b>MM7:</b> v	
Enviolo:	<b>MMi:</b> v	v

→ **Accessories**  
(See page. 30 to 35)



## CargoBike Classic Short

The CargoBike Classic Short is most similar to the original model, easy to steer, has a low centre of gravity and a wooden box where children can easily get in and out off. The unique four footed stand gives complete stability to the cargobike while loading and when parked. Also the magnetic safety belts are easy to use. Dimensions Cargobike short: length 228cm x width 63cm.

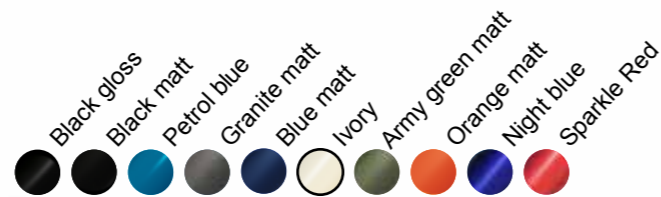

Discover this bike on our website or click through and discover our configurator

### → Available gear options

<b>Rollerbrakes:</b>	
Shimano 7v:	<b>NN7D</b>
Shimano 8v:	<b>NN8D</b>
Shimano 8v with coaster brake:	<b>NR8D</b>
<b>Discbrakes:</b>	
Shimano 7v:	<b>SS7D</b>
Enviolo:	<b>SSiD</b>
<b>Magura HS11 rim brakes:</b>	
Shimano 7v:	<b>MM7D</b>
Shimano 8v:	<b>MM8D</b>
Enviolo:	<b>MMiD</b>

→ For the version with electric assistance see page 4 to 5.

→ Accessories  
(See page. 30 to 35)



## CargoBike Cruiser Short

The CargoBike Cruiser Short is a vintage version of the Classic model with fat tyres for comfort, mudguards in matching frame colour, Brooks Aged leather saddle and handlebar grips and a retro style 35 lux headlight and Plateo rear light (both powered by the hub dynamo and with standlight function). There is no rear carrier rack fitted. Dimensions Cargobike short: Length 253cm x width 63cm



Discover this bike on our website or click through and discover our configurator

### → Available gear options

<b>Rollerbrakes:</b>	
Shimano 7v:	<b>NN7D</b>
Shimano 8v:	<b>NN8D</b>
Shimano 8v with coaster brake:	<b>NR8D</b>
<b>Discbrakes:</b>	
Shimano 7v:	<b>SS7D</b>
Enviolo:	<b>SSiD</b>
<b>Magura HS11 rim brakes:</b>	
Shimano 7v:	<b>MM7D</b>
Shimano 8v:	<b>MM8D</b>
Enviolo:	<b>MMiD</b>

→ For the version with electric assistance see page 4 to 5.

→ Accessories  
(See page. 30 to 35)



## CargoBike Classic Long

The CargoBike Classic Long is identical to the Short but with a stretched frame and box. It has the space to carry up to 3 children by adding an extra bench at the front, or 2 children on the rear bench and a baby in a Maxi Cosi or a baby/toddler seat in the front area. You can also carry a dog with a top cage or change the box to a box with a door in the side for easy entrance. In short, there are a lot of options available. Dimensions CargoBike long: length 253cm x width 63cm.



Discover this bike on our website or click through and discover our configurator

### → Available gear options

- |                                |             |
|--------------------------------|-------------|
| <b>Rollerbrakes:</b>           |             |
| Shimano 7v:                    | <b>NN7D</b> |
| Shimano 8v:                    | <b>NN8D</b> |
| Shimano 8v with coaster brake: | <b>NR8D</b> |
| <b>Discbrakes:</b>             |             |
| Shimano 7v:                    | <b>SS7D</b> |
| Enviolo:                       | <b>SSiD</b> |
| <b>Magura HS11 rim brakes:</b> |             |
| Shimano 7v:                    | <b>MM7D</b> |
| Shimano 8v:                    | <b>MM8D</b> |
| Enviolo:                       | <b>MMiD</b> |

→ For the version with electric assistance see page 6 to 8.

→ Accessories (See page. 30 to 35)



## CargoBike Cruiser Long

The CargoBike Cruiser Long is a vintage version of the Classic model with fat tyres for comfort, mudguards in matching frame colour, Brooks Aged leather saddle and handlebar grips and a retro style 35 lux headlight and Plateo rear light (both powered by the hub dynamo and with standlight function). There is no rear carrier rack fitted. Dimensions CargoBike long: length 253cm x width 63cm.

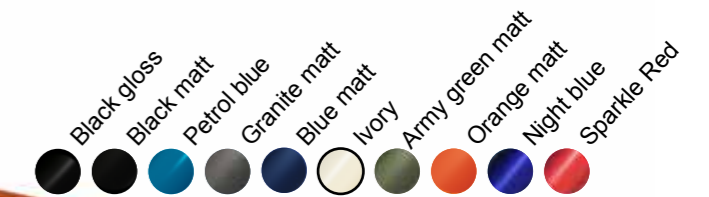

Discover this bike on our website or click through and discover our configurator

### → Available gear options

- |                                |             |
|--------------------------------|-------------|
| <b>Rollerbrakes:</b>           |             |
| Shimano 7v:                    | <b>NN7D</b> |
| Shimano 8v:                    | <b>NN8D</b> |
| Shimano 8v with coaster brake: | <b>NR8D</b> |
| <b>Discbrakes:</b>             |             |
| Shimano 7v:                    | <b>SS7D</b> |
| Enviolo:                       | <b>SSiD</b> |
| <b>Magura HS11 rim brakes:</b> |             |
| Shimano 7v:                    | <b>MM7D</b> |
| Shimano 8v:                    | <b>MM8D</b> |
| Enviolo:                       | <b>MMiD</b> |

→ For the version with electric assistance see page 6 to 8.

→ Accessories (See page. 30 to 35)



## CargoTrike Classic Narrow

The trike has more space than the Cargobike, it also is more stable at lower speeds. There is standard room for four children due to the two included benches. There is also a handy step on top of the mudguards to help them get in and out of the box. As an accessory there is a user friendly canopy and/ or box cover available. Dimensions trike narrow: length 210cm x width 85cm. Dimensions bottom surface: length 86cm x width 54.



Discover this bike on our website or click through and discover our configurator

### → Available gear options

**Discbrakes:**

Shimano 7v:  
Shimano 8v with coasterbrake  
Enviolo:

**SS7D**  
**SR8D:**  
**SSiD**



→ For the version with electric assistance see page 12 to 13.

→ Accessories

(See page. 30 to 35)



## CargoTrike Cruiser Narrow

The CargoTrike Cruiser Narrow is a vintage version of the Classic model with fat tyres for comfort, broad mudguards in matching frame colour, Brooks Aged leather saddle and handlebar grips and a retro style 35 lux headlight and Plateo rear light (both powered by the hub dynamo and with standlight function). There is no rear carrier rack fitted.

Dimensions trike narrow: length 210cm x width 85cm. Dimensions bottom surface: length 86cm x width 54.

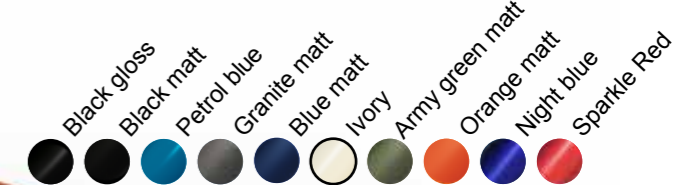

Discover this bike on our website or click through and discover our configurator

### → Available gear options

**Discbrakes:**

Shimano 7v:  
Shimano 8v with coasterbrake  
Enviolo:

**SS7D**  
**SR8D:**  
**SSiD**



→ For the version with electric assistance see page 12 to 13.

→ Accessories

(See page. 30 to 35)



## CargoTrike Classic Wide

The CargoTrike Classic Wide is similar in length to the Narrow, but is 10cm wider so it offers even more space for freight or children. As an accessory there is a box cover and a wooden cover available. This makes the Cargotrike Wide also perfect for transporting luggage.

Dimensions Trike Wide: length 210cm x width 95cm.

Dimensions bottom surface: length 86cm x width 65cm.



Discover this bike on our website or click through and discover our configurator

### → Available gear options

**Discbrakes:**

Shimano 7v:  
Shimano 8v with coasterbrake  
Enviolo:

**SS7D**  
**SR8D:**  
**SSiD**



→ For the version with electric assistance see page 14 to 15.

→ Accessories  
(See page. 30 to 35)



## CargoTrike Cruiser Wide

The CargoTrike Cruiser Wide is a vintage version of the Classic model with fat tyres for comfort, broad mudguards in matching frame colour, Brooks Aged leather saddle and handlebar grips and a retro style 35 lux headlight and Plateo rear light (both powered by the hub dynamo and with standlight function). There is no rear carrier rack fitted.

Dimensions Trike Wide: length 210cm x width 95cm.

Dimensions bottom surface: length 86cm x width 65cm.



Discover this bike on our website or click through and discover our configurator

### → Available gear options

**Discbrakes:**

Shimano 7v:  
Shimano 8v with coasterbrake  
Enviolo:

**SS7D**  
**SR8D:**  
**SSiD**



→ For the version with electric assistance see page 14 to 15.

→ Accessories  
(See page. 30 to 35)





## Rickshaw

Drivers and passengers can talk to each other comfortably and enjoy the surroundings in peace. The Rickshaw is a fantastic way to explore the city. This electric taxi is equipped with a Shimano Steps or Bafang mid-engine. This makes it very durable and also much cheaper to use than a car (the battery is charged again for 40 cent!). The extendable footboard ensures that passengers can board safely. The Riksja is standard equipped with thick ventilating cushions. Optionally, the canopy and/or warm foot rug can be ordered. The hood not only provides protection from the sun and canopy, but also gives a cozy look.

Dimensions: Length 290cm x width 102cm

- Black gloss
- Black matt
- Petrol blue
- Granite matt
- Blue matt
- Ivory
- Army green matt
- Orange matt
- Night blue
- Sparkle Red



Discover this bike on our website or click through and discover our configurator

### → Available gear options

Disc brakes:		steps	Bafang
Shimano 5v Mechanical:	<b>SS5</b>	V	V
Shimano 5v Di2:	<b>SS5 Di2</b>	V	
Enviolo:	<b>SSi</b>	V	V
Rohloff:	<b>SS14:</b>	V	V



Optional canopy bright red



Optional canopy matt black



Optional foot rug



Optional safety bracket





## Cleaner E-Trike

This Trike is ideal for cleaning companies. Whether you clean outside the roads, paths, parks or squares. With this electric Trike you can cycle everywhere in an instant, and you will have your terrain clean again in no time. The container is easy to take anywhere, and is easily removable. The container is secured with a lashing strap. Please note, **the bicycle will be delivered without a container.**

Sizes Cleaner Trike: length 210cm x width 105cm

- Black gloss
- Black matt
- Petrol blue
- Granite matt
- Blue matt
- Ivory
- Army green matt
- Orange matt
- Night blue
- Sparkle Red



Discover this bike on our website or click through and discover our configurator

### → Available gear options

Disc brakes:	steps	Bafang
Bafang 3v Automatic:	SS3	V
Shimano 5v Mechanical:	SS5	V
Shimano 5v Di2:	SS5 DI2	V
Enviolo:	SSi	V

### Rail for high weight load:

Heavy loaded trikes can be fitted with a special rail system which also functions as a steering limitation. This special rail system is standard on the Rickshaw and Daycare (this option is only available for the wide versions of the trike)



## Daycare E-Trike

The Daycare trike can transport a maximum of six young children (age +/- 2-6 years). Its also possible to mount a child seat on the back carrier to transport one extra child. Take note that: Older, taller children take more space, meaning less space remains. has standard strong disc brakes, roll bars, two benches in the longitudinal direction and easy front entry for the children.

- Black gloss
- Black matt
- Petrol blue
- Granite matt
- Blue matt
- Ivory
- Army green matt
- Orange matt
- Night blue
- Sparkle Red



Discover this bike on our website or click through and discover our configurator

### → Available gear options

Disc brakes:	steps	Bafang
Bafang 3v Automatic:	SS3	V
Shimano 5v Mechanical:	SS5	V
Shimano 5v Di2:	SS5 DI2	V
Enviolo:	SSi	V



safe disc brake



easy entry















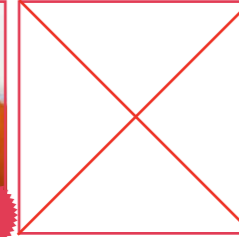

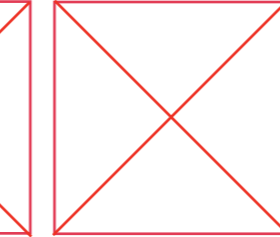

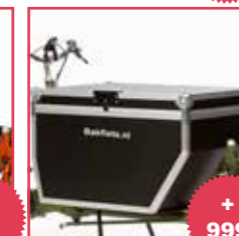

safe roll bars

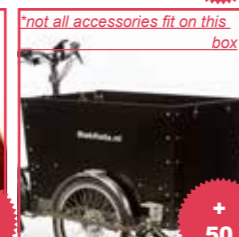
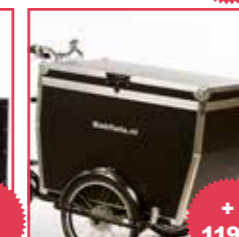

## → Box options

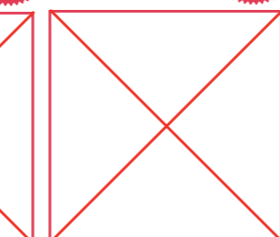
Below you will find an overview of all the different box options we offer. The business version is delivered without benches and seatbelts.

Short  
Long  
Trike W  
Shadow

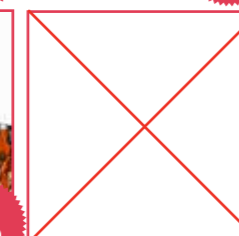
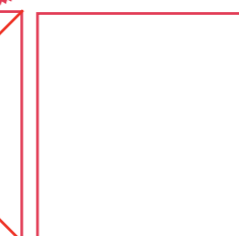
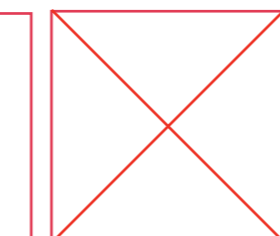
	Standard	Business	Black box	Flightcase	High black box	Box with entry hatch
Short	 Basic	 - 20		 + 929		
Long	 Basic	 - 20	 + 29	 + 999	 + 69 <small>only in black available Not all accessories fits</small>	 + 139 <small>only in black available</small>
Trike W	 Basic	 - 40	 + 50 <small>not all accessories fit on this box</small>	 + 1199		
Shadow	 Basic	 - 20	 + 269			

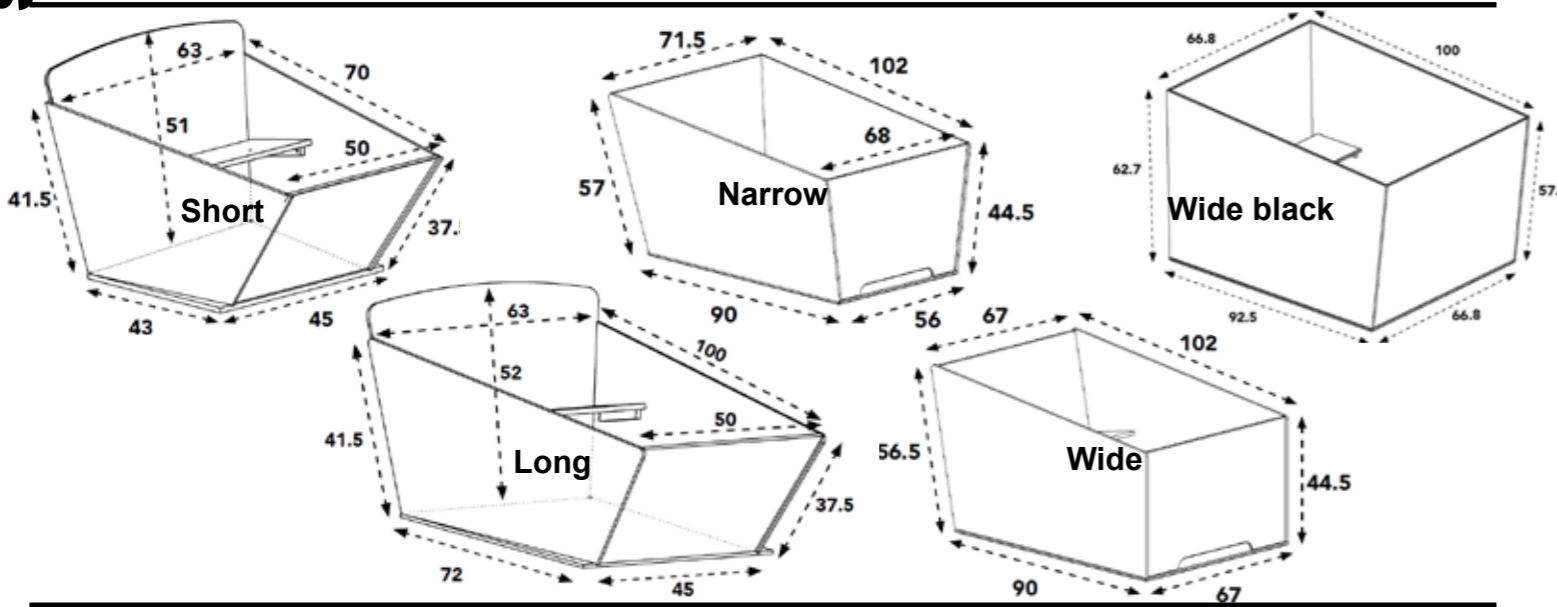

## → Options & Accessories

- Ventisit cushion single with backrest
  - Ventisit cushion double with backrest
  - Thin double cushion black (backpack material)
  - Headrest
  - Maxi-cosi bracket for mounting on bottom
  - Maxi-cosi bracket for mounting on bench
  - Black toddler sleep seat (9-18 months)
  - Black baby seat 0-9 months
  - Black toddler seat 9-18 months
  - Mounting bracket for baby / toddlerseat
  - Quick release set for baby/toddlerseat
  - Bracket for mounting front childseat on box bottom
  - Bracket for mounting front child seat on bench
  - Lock for canopy
  - Renewed Maxi-cosi easy bracket
  - Adaptors for Maxi-cosi easy (for mounting the Maxi-cosi easy against the back plate)
  - Quick release for Maxi-cosi easy model
- Accessories CargoBike Short and Long**
- Eyelet for chain / cable lock
  - Extra seat on steerer tube
  - Sunshade (cargobike long and short)
  - Locker under bench wood colour
  - Locker under bench black
  - Foldable canopy supports (CargoBike short)
  - Foldable canopy supports (CargoBike long)
  - Kickstand with spring function (only available as after market product)

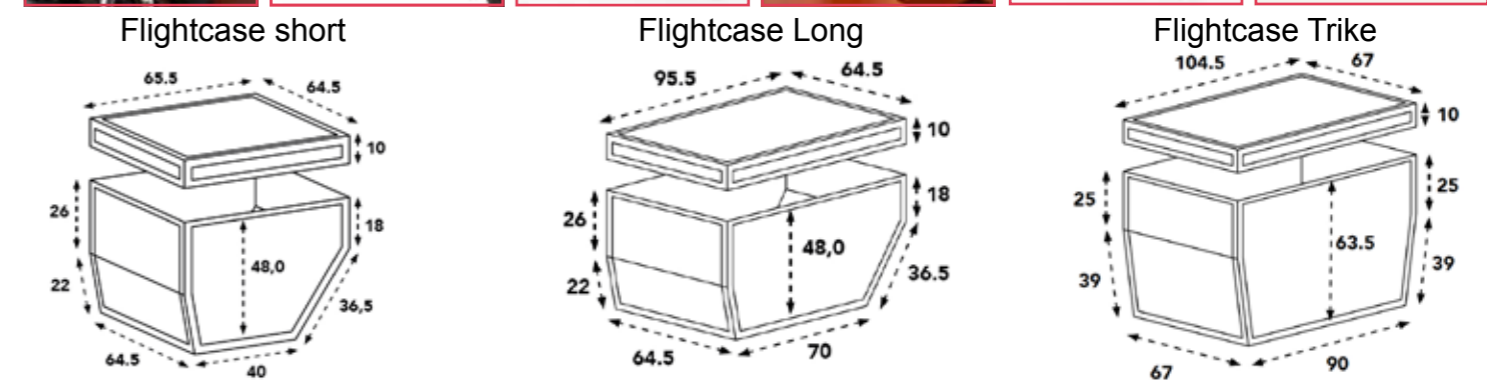
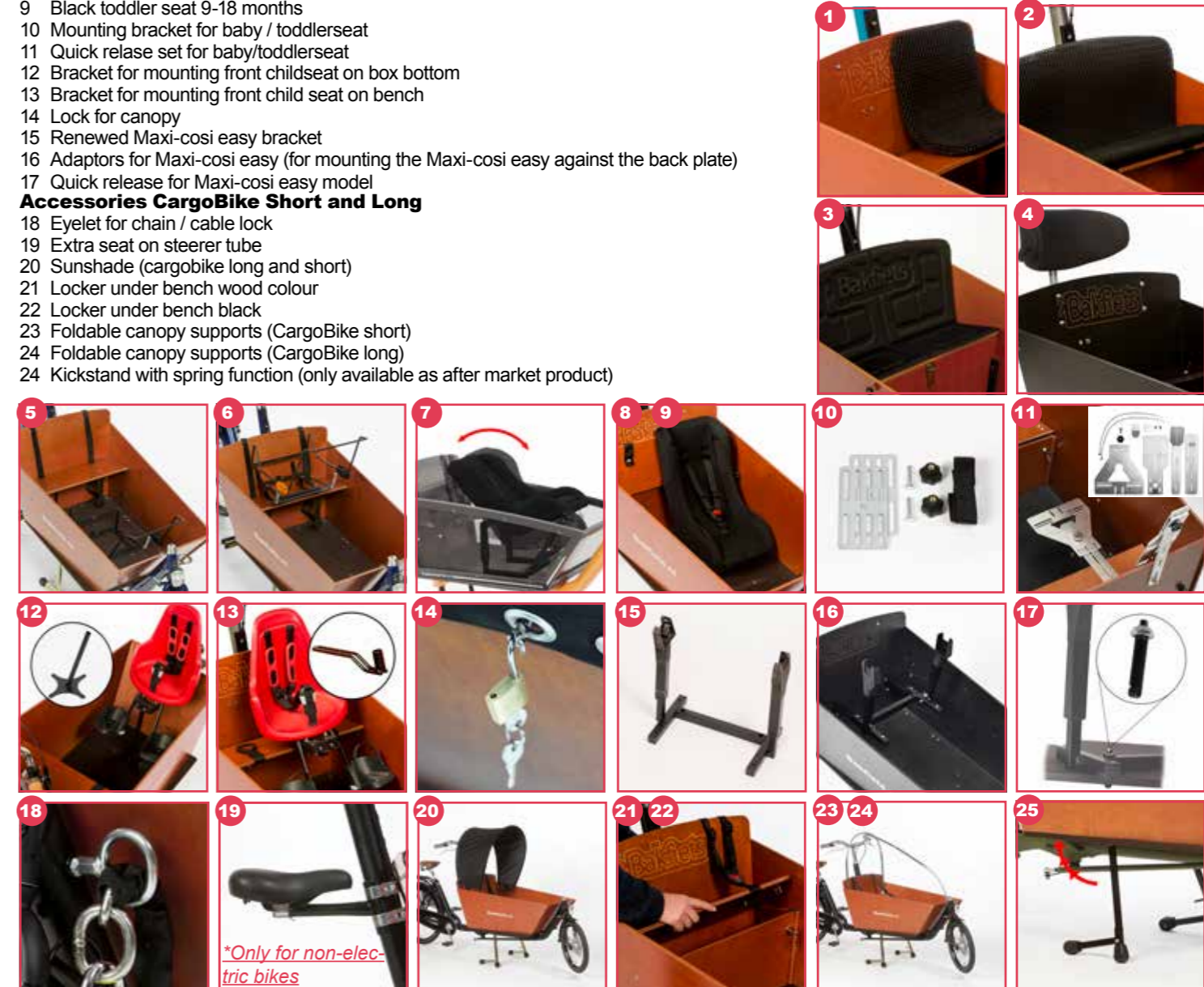



## Options & Accessories

### Accessories CargoBike Short

- 26 Flat box cover CargoBike short: black
- 27 Canopy CargoBike short: black
- 28 Canopy CargoBike short all-open: black
- 29 Canopy CargoBike short all-open: tweed
- 30 Canopy CargoBike short all-open: black matt

### Accessories CargoBike Long

- 31 Flat box cover CargoBike long: black
- 32 Flat box cover CargoBike long: tweed
- 33 Canopy CargoBike long: black
- 34 Canopy CargoBike long all-open: black
- 35 Canopy CargoBike long all-open: tweed
- 36 Canopy CargoBike long all-open: admiral blue
- 37 Canopy CargoBike long all-open: matt black
- 38 Canopy CargoBike long all-open: red
- 39 Canopy CargoBike long all-open: brown
- 40 Canopy CargoBike long all-open: ivory matt
- 41 Canopy CargoBike Long Roll-bar
- 42 Cushion double: Ventisit
- 43 Cushion double: tweed
- 44 Cushion double: admiral blue
- 45 Cushion double: matt black
- 46 Cushion double: red
- 47 Cushion double: brown
- 48 Cushion double: ivory matt
- 49 Cushion with high edge
- 50 Door panel in the side of the box (without mounting)
- 51 Dog bench and cage for CargoBike long
- 52 Ventisit floor mat (reduces unwanted noises from the box)
- 53 All-over cover CargoBike long: Black (heavy duty quality) | does not fit with canopy
- 54 Extra bench: redwood colour
- 55 Extra bench: black
- 56 Reduced bench: black (children can sit lower in the box)
- 57 Safety-bar with trim in frame colour
- 58 Safety-Roll-bar with trim in frame colour
- 59 Safety-bar in frame colour with trim in Stainless steel
- 60 Safety-Roll-bar in frame colour with trim in Stainless steel
- 61 Flat box cover Shadow: matt black
- 62 Canopy Shadow long all-open: matt black
- 63 All-over cover Shadow: Black (heavy duty quality) | does not fit with canopy

### Accessories Trike

- 64 Flat box cover trike: black (fits Narrow and Wide)
- 65 Canopy Trike Narrow with zipper: black
- 66 Canopy Trike Wide with zipper: black
- 67 Canopy Trike Narrow with zipper: tweed
- 68 Canopy Trike Wide with zipper: tweed
- 69 Canopy Trike Narrow with zipper: black matt
- 70 Canopy Trike Wide with zipper: black matt
- 71 Locker under bench trike (wide trike only (without mounting)
- 72 Box lid with gas damper (wide trike only) (without mounting)
- 73 All-over cover Trike (also fits over rain tent)
- 74 Ventisit floor mat trike wide (reduces unwanted noises from the box)
- 75 Cushion double with backrest



### The best components

Bakfiets.nl only uses the highest quality components available and works with the producers to get the best results, many of these parts are specially designed and made exclusively for us.



## A bakfiets.nl:

- Cargobike is made in Hoogeveen (Netherlands)
- Is the safest way to transport your children with a bike according to ADAC • Easy to ride and manoeuvre
- Kids can climb safely in the box because of the solid 4 leg stand
- Bakfiets.nl uses FSC approved wood
- The box is made from waterproof Phenolic coated multiplex
- The powder coating is 3 layers both durable and impact resistant
- Stainless steel components are used where possible
- Top quality accessories with upgrade options
- High resale value due to superb build quality

Bakfiets.nl thanks the following suppliers:

**SHIMANO**

**BAFANG**

E-BIKE DRIVE SYSTEMS



**spanninga**  
Keep ahead of light.

**POSTERAMA**  
THE SIGNATURE ON YOUR PRODUCT

**RYDE**  
OUR WORLD

**AXA BIKE SECURITY**

**Smt**  
SMART MANUFACTURER TEAMS

**Saccon.it**

**RUBIS**



**SCHWALBE**



ALU-CHAMPION

**ELVEDES**

Bike components.



TWICE INTERFLEX  
technical textile solutions

**BENGAL**  
DISC BRAKE

**Steco**

**ventisit**  
ventilating seat pad

**BUCHEL**

**arix**

**KOBOUT**



Melia.nl

kinderstoelen voor bakfiets en fietskar



**NETWORKERS**  
Yes They Do

Your cargo bike dealer

Printing errors and changes reserved [www.bakfiets.nl](http://www.bakfiets.nl)